

# Verification and evaluation method for the seismic performance of potable water mains lined with cured-in-place pipe (CIPP)

Hiromasa Ishizeki and Masakatsu Miyajima

## ABSTRACT

This paper presents earthquake damage surveys, experiments on seismic behavior, and a performance evaluation method using seismic calculation, for potable water mains lined with cured-in-place pipe (CIPP). CIPP is a trenchless technology that forms a new pipe within an existing pipeline for the purpose of renewal or corrosion prevention of aging pipes, and is used mostly in pipes with non-anti-seismic joints.

Japan has suffered significant damage to potable water pipelines caused by frequent seismic activities. It is reported that most of the resulting damage was water leakage caused by pullout of those joints that didn't have a separation preventing function, generally called non-anti-seismic joints.

For this research, an earthquake damage survey was first conducted on potable water mains in which PALTEM HL liners had been installed in the past. The survey showed that there were no damage reports for these pipelines. CIPPs were, therefore, judged to potentially contribute to the seismic improvement of pipelines with non-anti-seismic joints.

Next, physical experiments were conducted on pipe specimens lined with a fully-structural CIPP to verify seismic behavior. Even under loading conditions that reflected the past earthquakes with seismic intensities of 4 or above on the Japan Metrological Agency's (JMA) scaling, the CIPP protected host pipes from joint pullout, and the jointed pipelines exhibited behavior similar to a single, continuous pipe. The CIPP itself did not show any damage or leaks.

In addition, to establish a methodology to evaluate the seismic performance of CIPP that is installed inside existing pipes, a calculation model and its parameters were selected based on the seismic behavior observed and data obtained in the previous experiments. After that, the performance criteria required for CIPP were selected and material tests were conducted to determine the allowable stress using the fully structural CIPP.

This study has confirmed that CIPP improves seismic performance of old potable water pipelines and has enabled evaluation of seismic performance by seismic calculation in accordance with different site conditions.

## INTRODUCTION

CIPP is one of the trenchless technologies that create a new pipe within a deteriorated pipe buried underground. A CIPP liner is a composite material of liner tube with impregnated curable resin. A liner generally consists of non-woven fabric and often glass fiber. Figure 1 illustrates a typical structure of CIPP.

A resin-impregnated liner is inserted by a technique called inversion that uses air pressure to turn the liner inside out within an existing pipe. After insertion, the air pressure is maintained for the liner to closely fit to the host pipe until the resin cures and a CIPP is formed. The mechanism of inversion is illustrated in Figure 2.

Because the lining material is installed by inversion, it does not create loads such as friction force during insertion. Therefore, CIPP can be easily installed for a long distance in a pipeline even with curves and bends. In addition, installation of CIPP is not constrained by ground facilities, traffic circumstance or other buried obstacles because it requires no excavation except for a working pit at each end of a pipeline to be rehabilitated.

The length of deteriorated pipes that are reaching their design life is significantly increasing in Japan, and renewal and seismic strengthening of those pipes are becoming urgent issues. The conventional open-cut replacement method is still the primary countermeasure, however, there are many sites where pipes are buried under arterial streets, railroads, and rivers that make it difficult to excavate.

CIPP, a trenchless technology, is therefore employed for a broad range of infrastructure such as gas mains, potable water mains, sewers and irrigation lines. CIPP has become a common methodology especially in the Japanese gas and sewer industry because those industries have already instituted public guidelines [1], [2] for use of CIPP. These guidelines also define seismic performance of CIPP in term of leak prevention.

On the other hand, in the potable water field, CIPP is not yet publicly classified as an industrial standard for renewing and seismically strengthening deteriorated mains. Despite the fact that CIPP is not yet commonly accepted in the Japanese water works industry, it is believed that it is capable of a certain degree of seismic resistance performance. A verification study on the seismic performance of CIPP for potable water is reported in this paper.

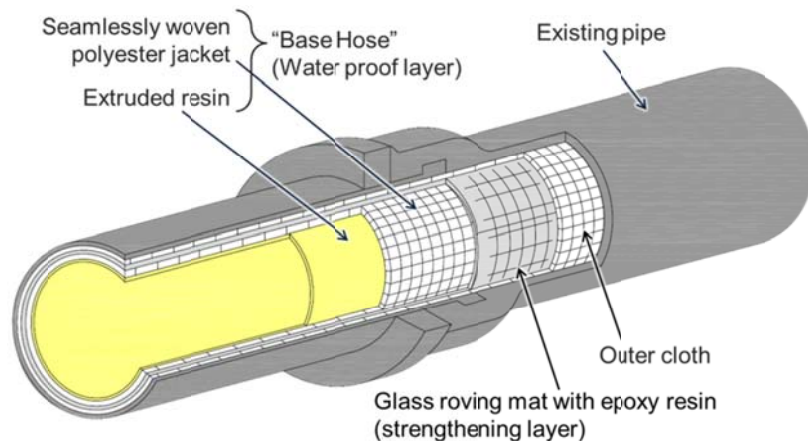

Figure 1. A typical structure of a CIPP (PALTEM Super-HL Liner as an example)

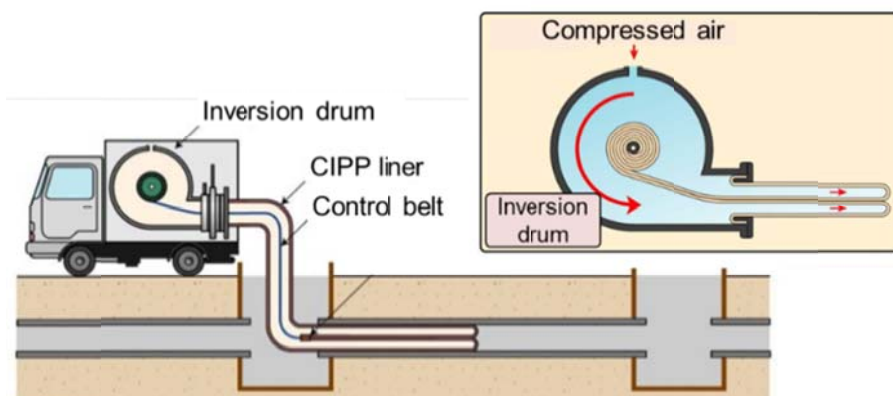

Figure 2. Inversion mechanism

## RESEARCH ON CIPP INSTALLED IN QUAKE-STRICKEN AREAS

Ashimori Industry Co., Ltd., Osaka, Japan, has been providing and installing CIPP since 1980 under its technique brand name “PALTEM” and more than 90% of their works by length were performed in Japan including areas stricken by major earthquakes. In the 35+ years of PALTEM history, its products have experienced at least 6 major earthquakes with a seismic intensity of more than 6-upper on the rating system of the Japanese Meteorological Agency, not including aftershocks. However, there has been no report of leak or failure (at least not as a post-quake damage report) from stricken cities in which PALTEM HL (hose lining) liners were used. It should be noted that portions of PALTEM’s early stage liners are semi-structural and non-structural.

Before this study project, we had already conducted post-quake research [3] on PALTEM CIPP installations after “The Great Hanshin Earthquake” which hit cities such as Osaka and Kobe in the mid-west portion of Japan in 1995. In one of the major cities in the region, the municipal water authority found no leak in water mains retrofitted with PALTEM CIPP, while about 1,000 defects were reported in the entire 4,000 km distribution network. In the same city, a gas distributor reported no leakage from their gas mains that were lined with PALTEM liners, and our own sewer inspection also confirmed no leaks. Similar results were confirmed in our research and inspection after “the 2011 Tohoku Earthquake”.

Our research was extended for this study project and was focused on potable water mains. Cities, towns, boroughs and villages were selected in municipal areas that had been stricken by major earthquakes with the threshold of seismic intensity equal to 6-upper as it is the specified class for seismic resistance assessment of new water main installation in Japan. Some locations were further narrowed down to “district levels” if, in a municipal level, ground liquefaction was reported during earthquakes.

Table 1 shows the result of crosschecking between official quake damage reports and Ashimori’s past installation records in the selected areas. About 6.7 km of PALTEM CIPP were installed in municipalities stricken by earthquakes of seismic intensity 6-upper or above. 30 km were installed in areas in which ground liquefaction was reported. No leak or failure was reported from these municipalities or areas.

TABLE 1. CROSSCHECKING BETWEEN QUAKE REPORTS AND INSTALLATION RECORDS

Dates	Earthquakes	Locations (Prefectures)	Installation records (meter)			Damage Status
			Seismic intensity ≥ 6-upper	Ground liquefaction Reported		
				Municipal level	“District” level	
Jan/17/1995	Great Hanshin	Hyogo	1,143	1,143	88	No damage report
Oct/06/2000	West Tottori	Tottori	-	161	TBC	
Oct/23/2004	Chuetsu	Niigata	132	2,332	1,423	
Mar/25/2007	Noto	Ishikawa	40	-	-	
Jul/16/2007	Chuetsu Offshore	Niigata	132	-	-	
Mar/11/2011	Tohoku	Miyagi	571	538	83	
		Fukushima	125	152	TBC	
		Ibaraki	4,547	4,678	TBC	
		Chiba	-	1,357	TBC	
		Saitama	-	2,465	TBC	
		Tokyo	-	4,278	TBC	
		Kanagawa	-	12,949	1,310	
		Total	6,690	30,053	2,904	

TBC = to be confirmed



Figure 3. Joint pullout in a ductile iron pipe, [5]

Our research has also found that PALTEM CIPP survived in existing ductile iron pipes with conventional non-seismic-resistant joints. A research of Investigative Commission 2013 for Seismic Strengthening of Pipelines [4] over existing pipes has found that failure ratios of existing water pipelines were significantly higher for steel pipes with screwed joints, cast iron pipes (CIP) and ductile iron pipes (DIP) than for other types. The majority of failures were from joint pullout in ferrous pipes. An example of joint pullout in a DIP is shown in Figure 3.

These iron pipes without seismic-resistant joints are usually old and likely to be scheduled for rehabilitation or replacement. In fact, among 380 km of water main rehabilitations with PALTEM CIPP, approximately 65% were installed in old ductile iron and cast iron pipes. Even though the CIPPs have been used mainly on those types of pipe that are relatively weak in earthquake resistance, our research has revealed the fact that there were no failure reports after severe earthquakes. Hence, it can be deduced that the CIPP installations have seismically strengthened those existing pipelines with non-anti-seismic joints.

## VERIFICATION OF SEISMIC BEHAVIOR

When verifying seismic behavior of a pipeline that is retrofitted with CIPP, it should not be ignored that CIPP always exists inside a host pipe. CIPP is not directly buried underground, and it rather forms a multi-layer structure by closely fitting to the interior wall of an existing pipe. Therefore, the host pipe's seismic behavior, i.e. joint displacement behavior, influences the CIPP's seismic behavior.

In the past, an experimental study [3] had been conducted using a non-structural "hose liner" to verify if water tightness was maintained in an event of joint pullout. The result was favorable and it was also found, after gathering long-term experience in lining works and continuing fundamental studies, that joint displacement is less likely to occur if a CIPP was inside a host pipe.

CIPP's three characteristics related to pull-out resistance: close-fitting by inversion pressure, circumferential expansion by internal water pressure and bonding strength of epoxy resin are assumed to be the main causes for the non-displacement phenomena. Figure 4 illustrates a structure of a host pipe retrofitted with a CIPP and the reinforcing characteristics of CIPP.

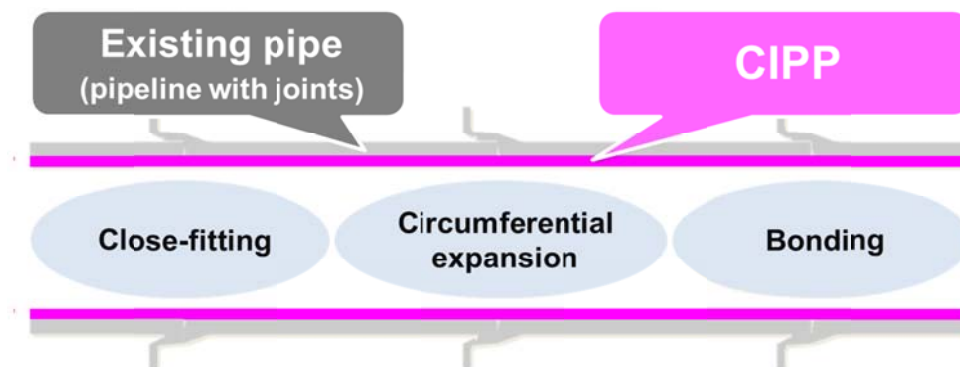

Figure 4. Three reinforcing effects of CIPP

## TESTS FOR FRICTION FORCE MEASUREMENT

Joint pullout occurs in an earthquake when a force that displaces a joint, namely pullout force, is greater than the pullout resistance force, according to Kumaki and Miyajima [6]. The joint pullout force develops from the friction force between the ground and an existing pipe and it is assumed to be  $0.0098 \text{ N/mm}^2$  according to a seismic design standard in Japan [7]. On the other hand, the pullout resistance force in a pipe retrofitted with a CIPP is presumed to develop from the friction force between the host pipe and the CIPP.

In order to confirm “non-slidability” between a host pipe and a CIPP, a test for friction force capability was conducted. For this test, PALTEM Super-HL, a fully structural CIPP liner was installed in a short section of steel pipe, then an axial load was applied from the top end of the vertically placed steel pipe, and the load was measured at the point that interface slip started between the CIPP and the steel pipe. The friction stress is calculated by dividing the load measured by the contact area between the host pipe and the CIPP. Three specimens were prepared for this test. In two of them (No.2 and 3), a thin nylon tube sheet was installed to intervene between the CIPP and the steel pipe to eliminate the bonding strength at the interfaces. Figure 5 illustrates the test setup and the results are shown in Table 2.

In specimen No.1, for which both the close-fitting effect by inversion pressure and bonding strength of resin are acting, the frictional resistance between the CIPP and the steel pipe was 40 times greater than assumed to act between the ground and an existing pipe. In specimens No.2 and No.3 with only the close-fitting effect, the frictional resistance was 2.5 times greater. Also, in another reference test, close-fitting and circumferential expansion by internal water pressure generated a friction resistance that was about 10 times greater than the standard assumption for friction resistance between ground and a steel pipe. In a real lining situation, all the three effects act simultaneously. The tests proved that the friction resistance between a CIPP and a host pipe was far greater than the maximum force assumed to be developed between a host pipe and the ground that is used in the Japanese seismic design standard [7]. Therefore, it can be anticipated that joint displacement hardly ever occurs even under an earthquake motion if a CIPP is installed inside a jointed pipeline.

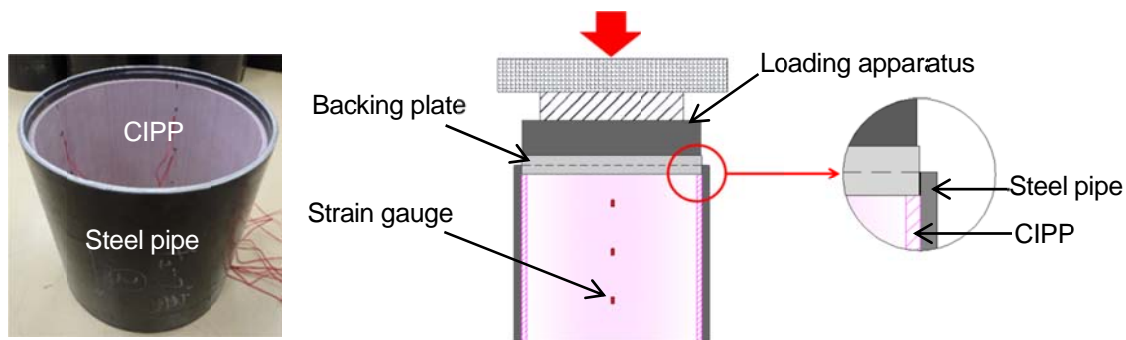

Figure 5. Test setup

TABLE 2. RESULTS OF FRICTION FORCE TEST

CIPP		“Super-HL” $\Phi 300$ , $t=4.0 \text{ mm}$			Reference test
Host pipe		Steel pipe, $\Phi 300$ , $L=300 \text{ mm}$			
Specimen		No.1	No.2	No.3	
Intervening sheet		-	Material A	Material B	Material A
CIPP's Properties	Close-fitting	✓	✓	✓	✓
	Circumferential expansion	-	-	-	✓ (0.75MPa)
	Bonding	✓	-	-	-
Friction force ( $\text{N/mm}^2$ )		0.411	0.025	0.025	0.096

## PHYSICAL TESTING FOR VERIFYING SEISMIC BEHAVIOR

Physical simulation tests were performed with jointed specimen pipes with CIPP installed to observe seismic behavior. The main purposes of these tests are as follows;

- 1) To observe joint displacement behavior under a load that simulates an earthquake.
- 2) To measure the load that causes joint displacement.
- 3) To measure the load that causes a defect in CIPP.

For these purposes, a test specimen was prepared as follows;

- 1) A pair of ID 300 mm, L=6 m, mortar-lined ductile iron pipes were connected via non-anti-seismic joints.
- 2) A  $t=0.2$  mm nylon tube was inserted. This nylon tube was used in order to create the most severe condition by eliminate the bonding strength between the host pipe and the CIPP which, in an actual installation, depends on interior surface status such as quality of cleaning or roughness due to deterioration.
- 3) A DN 300 mm,  $t=4$  mm CIPP was installed through the two connected ductile iron pipes.

The stages of specimen preparation are shown in Figure 6 and the structure of the joint is illustrated in Figure 7.

The test specimen of ductile iron pipes with installed CIPP was then subjected to the following test procedure;

- 1) Hydraulic jacks were installed on both the horizontal sides of the test specimen and longitudinal load was applied.
- 2) 0.75 MPa internal water pressure was maintained during the longitudinal loading so the test specimen simulated a pipe under internal service pressure.
- 3) Joint displacement was measured by gauges that were installed around the joint.



Figure 6. Stages of specimen preparation

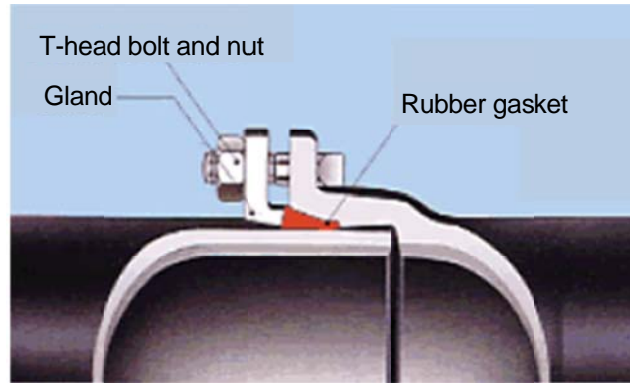

Figure 7. Structure of joint, [8]

The level of longitudinal load applied to the pipe specimen in this experiment was determined as follows;

- 1) The loading level must be high enough that joint pullout would occur in an existing pipe (without CIPP). Joint pullout force is generated by stress that acts on a ductile iron pipeline due to an earthquake, according to Kumaki and Miyajima [6].
- 2) Equation 1, referred to in Japan Water Works Association's guideline [7], is employed to calculate a necessary seismic load. This is one of standard formulas in Japan that was obtained based on past earthquake experiences and is used to calculate axial stress for a seismic intensity of 4 or above.
- 3) The equation gives an axial load of 27.69 kN where joint pullout force starts exceeding pullout resistance strength. For this experiment, 60 kN is used to provide a safety factor of approximately 2.

$$R = \sigma_{2L} \times A = \frac{\pi \cdot D \cdot \tau \cdot L}{2A} \times A \quad (1)$$

Where,

- $R$  : Joint pullout force
- $\sigma_{2L}$  : Axial stress in Level-2 seismic motion
- $A$  : Cross-sectional area of pipe
- $D$  : Outside diameter of pipe (300 mm)
- $\tau$  : Friction force between pipe and ground (=0.0098 N/mm<sup>2</sup>)
- $L$  : Length of pipe (6,000 mm)

The experimental setup is shown in Figure 8.

The results of the experiment are summarized as follows;

- 1) Joint displacement (pullout) was not observed even under the 60-kN load.
- 2) The load was then increased until joint displacement occurred, and approximately 400 kN was needed to cause joint displacement.
- 3) The CIPP inside the ductile iron pipeline did not suffer any damage nor showed any leakage through the entire experiment.



Figure 8. Experimental setup

The joint in the pipeline specimen with CIPP installed did not show a displacement under an axial load that is twice the calculated earthquake load. The load that finally caused joint displacement was 400 kN which is 15 times greater than the calculated earthquake load. The bonding strength of the curable resin was eliminated by the intervening nylon tube between the CIPP and the host pipes. In an actual CIPP watermain installation, a CIPP is typically strongly secured by bonding of epoxy resin inside the host pipe.

The two tests showed that, under the conditions simulated, a jointed pipeline with CIPP installed behaves like a single, continuous pipe including the joint. From the observation that the joint pullout behavior under seismic motion was suppressed by CIPP, it can be said that the seismic performance has improved in comparison to a pipeline with a non-anti-seismic joint. In addition, the CIPP showed no structural defect even though it was exposed to a load that is 15 times greater than the calculated seismic load. Moreover, it maintained the design burst pressure of 5.0 MPa under a burst test that was performed after the loading test. Hence, the structural CIPP is assumed to satisfy the required seismic strength both during and after seismic loading.

## **EVALUATION METHOD BASED ON SEISMIC CALCULATION**

The previous sections have shown CIPP's capability of suppressing joint pull-out behavior and seismic strength performance, however, it is not enough to provide only a generalized seismic performance evaluation of CIPP. Site conditions need be reflected in a seismic calculation method to verify if a CIPP's strength is fully satisfied under an earthquake. To evaluate the seismic strength of a CIPP installation, a method is presented below to compare the seismic strain acting on the CIPP and the CIPP's allowable strain.

### **Calculation of Strain Acting on CIPP**

The "Seismic Design and Construction Guidelines for Water Supply Facilities" of Japan Water Works Association (JWWA) [7] specifies a seismic design calculation method based on the response displacement method for welded steel pipes as a continuous pipeline. However, two issues need to be addressed before immediately using the specified equation.

The first one is that CIPP is not directly buried underground and it lies within a jointed pipeline. When calculating strain that is generated on a CIPP, the joint displacement behavior under seismic motion needs to be reflected. To address this issue, the previously explained loading test proved that the jointed ductile iron pipeline with the CIPP installed behaved similarly to a single, continuous pipe. In other words, a ferrous pipeline jointed with old, non-anti-seismic joints but retrofitted with a CIPP can be considered as a continuous pipe with ferrous outer material. Hence, it is concluded that the above equation for seismic strength calculation of welded steel pipe is applicable in the case of a pipeline retrofitted with a fully structural CIPP.

The second issue is lack of validity to apply the seismic strain that is calculated based on material characteristics of steel pipe for evaluation of CIPP, a plastic pipe. There is a great difference in the tensile elastic modulus of the two different pipe materials. To address this issue, the tensile elastic modulus of CIPP is employed so that seismic strain acting on the model pipeline is greater than that for the ferrous pipe to provide a conservative calculation.

With these assumptions, JWWA's seismic calculation method for welded steel pipe can be applied to CIPP in a jointed ferrous pipe with the characteristics of the plastic material being considered.

### **Setting CIPP's Allowable Strain**

Because a fully structural CIPP does not rely on the strength of the existing pipe, its allowable strain must be determined based only on the CIPP's physical properties. To determine the allowable strain for seismic design calculations, earthquakes are classified into two levels, a Level-1 earthquake and a Level-2 earthquake, in accordance with the Japanese seismic design practice for water facilities [7].

A Level-1 earthquake is defined as an earthquake that likely occurs over the service period of a pipe, and it is generally estimated to be of a seismic intensity of 6-lower or less. A Level-2 earthquake is defined as an earthquake that barely occurs over the service period but could be catastrophic, and it is generally estimated to be of a seismic intensity of 6-upper or above.

For Level-1 earthquakes, it is defined in the guideline that a requirement for seismic performance of CIPP is to satisfy "the limit state in which the dynamic property of CIPP material falls within the elastic range" [7]. Although ferrous materials generally have a clear yield point as a boundary between the elastic range and plastic



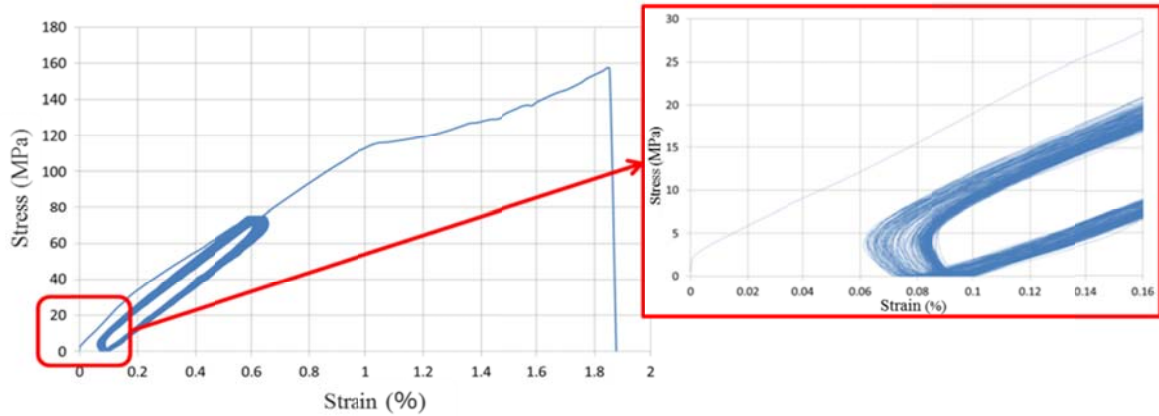

Figure 9. Record of cyclic strain test

range, the stress-strain relation of CIPP material has no clear yield point. Therefore, as an alternative method to judge the elastic range of the CIPP used in the seismic experiments, cyclic strain tests were performed and residual strain was measured.

A 0.6% strain was cyclically applied on a flat test piece of the CIPP at the rate of 5 mm/min for 300 repetitions, as shown in Figure 9. It was confirmed that the residual strain is 0.1% or less after the cyclic strain tests.

In general, a stress level that leaves 0.2% strain is assumed as the yield stress for materials such as glass, concrete, plastic, and rubber. Hence, we decided that the result of the cyclic test showed a satisfactory margin of safety. In addition, the test pieces didn't show any reduction in strength after the cyclic test. The 0.6% strain maintains safety factor of 3 to the breaking stress of this CIPP material, which is approximately 2.0%. The test setup is shown in Figure 10 and Table 3 shows the results.



Figure 10. Setup of Level-1 cyclic strain test

TABLE 3. RESULT OF LEVEL-1 CYCLIC TEST

Strain applied (%)	Test Specimen	Residual strain after cyclic test (%)	Tensile strength after cyclic test (MPa)
0.60	1	0.07	160.6
	2	0.09	157.4
	3	0.07	163.2
-	Initial value	-	159

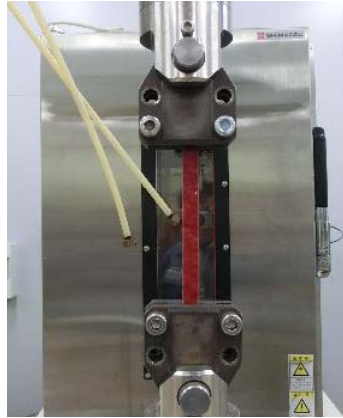

Figure 11. Setup of Level-2 cyclic strain test

TABLE 4. RESULT OF LEVEL-2 CYCLIC TEST

Strain applied (%)	Test specimen	Physical status after cyclic test (%)	Tensile strength after cyclic test (MPa)
1.20	1	No damage	137 (average)
	2		
	3		
-	Initial value	-	140

For Level-2 earthquakes, the seismic resistance of CIPP is defined to satisfy “the limit state in which no water leak occurs even under partially plasticized status” [7]. Cyclic strain simulating a Level-2 seismic motion was applied to check the integrity of CIPP and determine allowable strain under Level-2 seismic motion.

1.2 % strain was applied on flat test pieces at the frequency of 5 Hz for 500 repetitions. No damage such as rupture was found and, again, no reduction in strength was confirmed by a tensile test after the cyclic strain tests. The 1.2% strain maintains a safety factor of 1.5 to the breaking stress of this CIPP material. Figure 11 shows the test setup and the results are shown in Table 4.

### An Example of a Seismic Design Calculation

In this paper, a seismic design calculation method for CIPP has been theorized as follows.

- 1) The equation used is the same as one for welded steel pipe since the presence of the CIPP integrates the host pipe’s jointed structure and the entire pipeline becomes as if a single-layer, continuous pipe. However, only the CIPP’s material properties are to be plugged into calculation.
- 2) The calculated strain is compared only to the allowable strain of the CIPP because, when the seismic performance of a full-structural CIPP is to be verified, material properties of host pipe should be ignored.

The equation used employs the response displacement method which well reflects the response properties of the ground and enables the consideration of dynamic ground motion based on a static analysis of ground displacement and strain. A model calculation is presented below with ground conditions and other calculation variables chosen from JWWA’s Guideline [9] as shown in Figure 12.

The tensile elastic modulus and the linear expansion coefficient of PALTEM’s fully structural CIPP are employed as the physical properties of CIPP. Figure 12 illustrates the model conditions and the calculation results are presented in Table 5.

As the result of the model calculation, seismic strains are within the allowable strain of CIPP for both Level-1 and Level-2 earthquake simulations. Under this condition setting, the CIPP satisfies the required seismic strength performance.

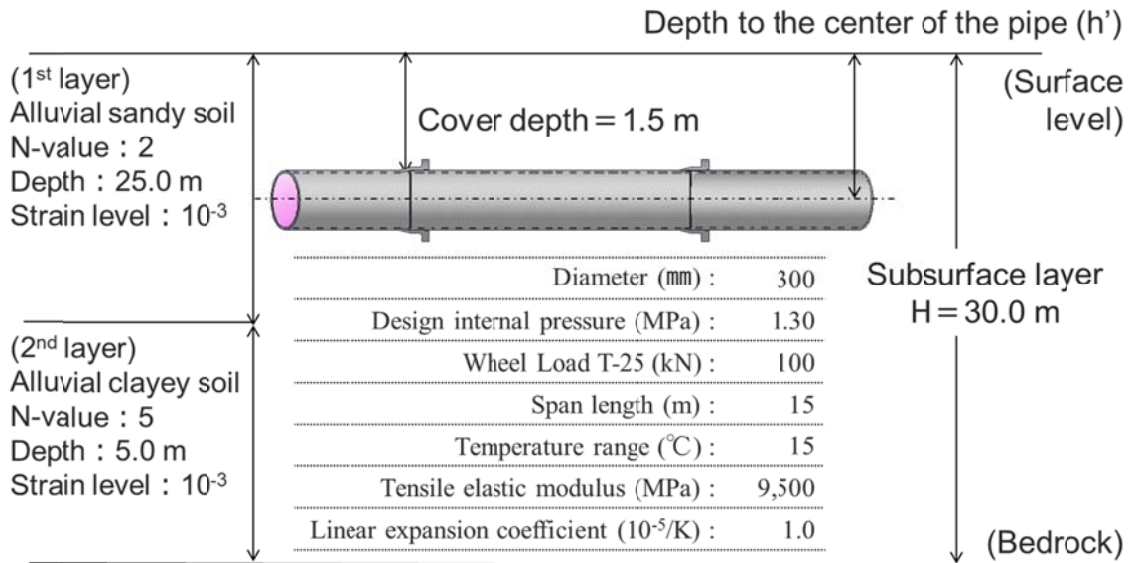

Figure 12. A model ground condition for verification, [9]

TABLE 5. VERIFICATION RESULT OF SEISMIC PERFORMANCE

		Level-1	Level-2
Normal load	Design internal pressure	0.152%	
	Vehicle load	0.046%	
	Temperature change	0.015%	
	Unbalanced subsidence	0.010%	
Seismic load		0.060%	0.502%
Total Strain in axial direction		0.283%	0.725%
Allowable strain		0.600%	1.200%
<b>Result of verification</b>		<b>Within allowable strain</b>	<b>Within allowable strain</b>

## CONCLUSION

This study has included a survey of past CIPP installations in quake-stricken areas, physical tests on seismic behavior of simulated pipes with CIPP installed, and verification of seismic strength of CIPP by calculation under model ground conditions. The study concludes as follows.

- 1) There was no failure report of CIPP from areas that suffered seismic intensity of more than 6-upper and/or liquefaction.
- 2) A fully structural CIPP rehabilitation suppresses joint pull-out behavior of the host pipe through the friction force that develops between the CIPP and host pipe.
- 3) It required a more than 15 times greater load than the calculated seismic load to generate joint displacement in a pipeline that was retrofitted with the fully structural CIPP.
- 4) The fully structural CIPP didn't show any leak or damage even under the load that was 15 times greater than the seismic load.
- 5) A method has been developed to calculate the stress that acts on the CIPP-installed pipe in an earthquake using the response displacement method already in use for welded steel pipe.
- 6) A way to determine the allowable strain of a CIPP for Level-1 and Level-2 earthquakes has been proposed. (In the case of PALTEM Super-HL CIPP, this is 0.6% and 1.2%, respectively.)

As the result of verification and evaluation conducted during this study, it can be stated that CIPP does strengthen old potable water mains against seismic damage. A seismic design calculation reflecting different site conditions is now possible and represents a way to evaluate the seismic performance of CIPP with clearer criteria.

Future research is expected to include ground deformation status such as subsidence by broader verifications using both theoretical data to be obtained from experiments/analysis and actual data from past installation records.

## REFERENCES

- [1] Japan Gas Association (JGA). 2009. "Guideline for Maintenance Measure of Mains and Laterals".
- [2] Japan Sewage Works Association (JWWA). 2017. "Guideline for Design and Construction Management of Pipe Renovation Methods".
- [3] Association for Disaster Prevention Research. 1997. "Study on Earthquake Damage to Buried Pipes and Seismic Resistance of Pipes with Hose Lining".
- [4] Investigative Commission 2013 for Seismic Strengthening of Pipelines. 2014. "Investigative Report for Seismic Strengthening of Pipelines", p. 47.
- [5] Okabe, Y. 2012. "Restoration Support and Earthquake Disaster Countermeasure for Water Pipelines", presented at the 2011 Tohoku Earthquake Symposium for Potable Water and Sewer.
- [6] Kumaki, Y. and Miyajima, M. 2012. "Study on Earthquake Damage in Ductile Iron Pipe Joint", Japan Society of Civil Engineering's paper collection A1 (Structural and earthquake engineering), Vol. 68, No. 4, pp. I195 - I201.
- [7] Japan Water Works Association (JWWA). 2009. "Seismic Design and Construction Guidelines for Water Supply Facilities", I. General, pp.28-29, p. 91, pp.262-263, and pp. 264-266.
- [8] Japan Ductile Iron Pipe Association. 2000. "Evolving ductile iron pipe".
- [9] Japan Water Works Association (JWWA). 2009. "Seismic Design and Construction Guidelines for Water Supply Facilities", Design Case Studies, p. 43.